

GRIFA Radantriebsmotor B250 mit Trommelbremse

Artikelnummer: 14 01 04 015

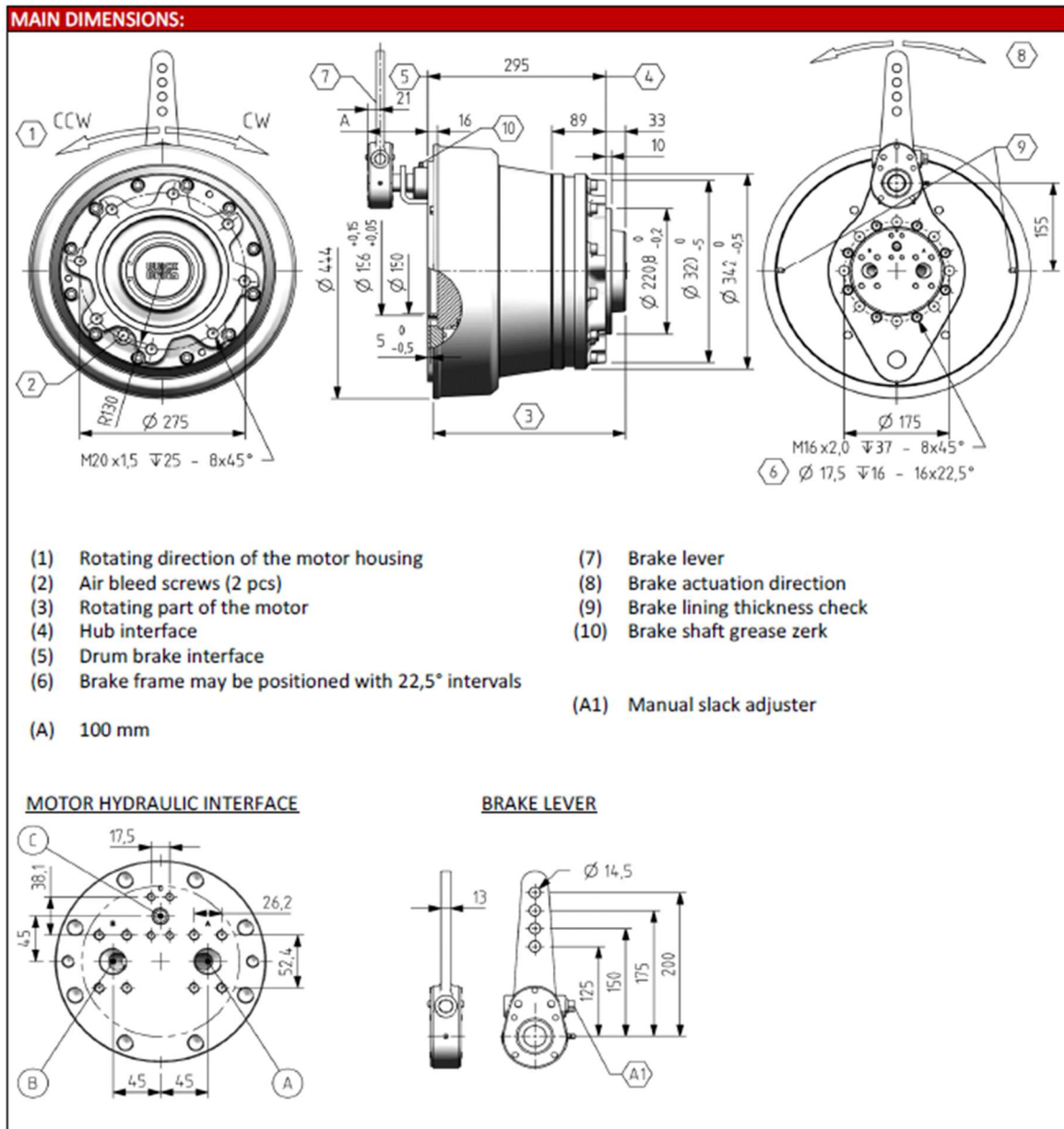

HYDRAULIC CONNECTIONS:

Port:	Type:	Size:	Pmax: ⁶⁾
A / B	WORKING LINES		350 bar
	ISO 1179-1	G3/4"	
	ISO 6162-1 type 1	1" flange (SAE 3000 psi), M10 screws	
C	CASE DRAIN		40 bar
	ISO 1179-1	G3/8"	
	ISO 6162-1 type 1	1/2" flange (SAE 3000 psi), M8 screws	
-	-	-	-

⁶⁾ Max. potential pressure in port. See performance for allowed operating pressure.